

TANITA

Dual frequency body composition monitor
with integrated Bluetooth technology

innerScan®
DUAL

RD-545HR

EN

Instruction manual

Read this Instruction Manual carefully and keep for future reference.

PL

Instrukcja obsługi

Przeczytaj uważnie tę instrukcję obsługi i zachowaj ją na przyszłość.

Introduction	1
Features and functions	1
For your safety	3
Getting accurate readings	4
Preparations before Use	5
Initial setup (Type 1) Setup via smartphone	6
Initial setup (Type 2) Manually without smartphone	8
Taking measurements	10
Taking measurements with auto-recognition	11
Measuring with an ID number (Call measurement)	13
Taking measurements without registering (Guest user measurements/Weight-only measurements)	14
ID selection mode	15
Measurement in progress	15
Reviewing measurement results (Whole body)	16
Reviewing measurement results (By body part)	17
Reviewing measurement results (Abnormal)	18
Changing personal data	19
Erasing personal data	20
Body composition guide	21
Troubleshooting	28
Specifications	29

INTRODUCTION

Thank you for purchasing this TANITA Body Composition Monitor.

This monitor is one of a wide range of home health care products produced by TANITA.

This Instruction Manual will guide you through the setup procedures and outline the key features of this monitor. Additional information on healthy living can be found on our website www.tanita.eu. TANITA products incorporate the latest clinical research and technological innovations.

All data is monitored by the TANITA Medical Advisory Board to ensure accuracy.



⚠ Safety precautions

Do not use the Body Composition Monitor if you have an electronic medical implant such as a pacemaker, as it passes a low-level electrical signal through the body which may interfere with the operation of the implant.

Pregnant women should only use the weight function. Other functions are not intended for use when pregnant.

Important notes for users

This Body Composition Monitor is intended for adults and children (age 5-17) who have inactive to moderately active lifestyles, and adults with athletic lifestyles.

Thanks to major investment in the latest BIA Technology and sports science research, TANITA has upgraded the Athlete Mode function to make measurements more accurate and suitable for a wider range of users.

Who should use Athlete Mode?

Adults aged 18 years and over who either:

- Train or exercise for 12 hours or more a week and have been doing so for at least six months.
- Are body builders.
- Are professional athletes who want to monitor their progress at home.
- Have a lifetime history of fitness and who used to do more than 12 hours a week but do less now.

Recorded data may be lost if the unit is used incorrectly or is exposed to electrical power surges.

TANITA cannot accept any responsibility for losses incurred due to the loss of recorded data.

TANITA cannot accept any responsibility for damages or losses incurred through the use of this product or any third-party claims.

Note: Body fat percentage estimates will vary with the amount of water in the body, and can be affected by dehydration or over hydration due to such factors as alcohol consumption, menstruation, illness, intense exercise, etc.

FEATURES AND FUNCTIONS

Front

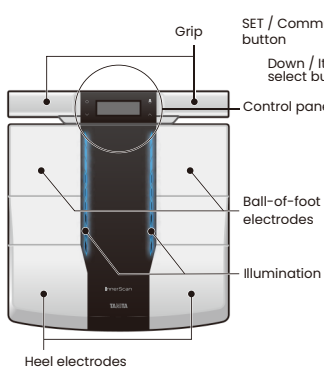

Back

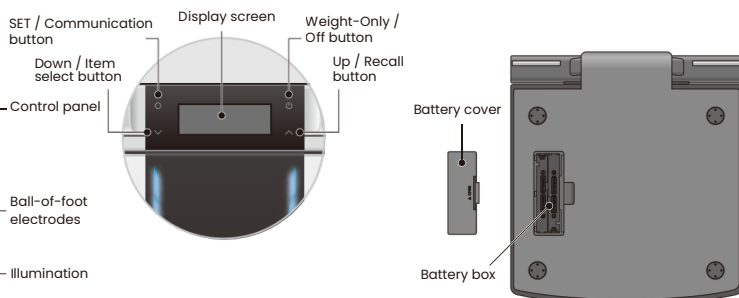

Location Code



Quick Start Guide





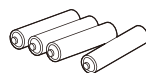

Accessories

AA-Size Batteries(4)



FOR YOUR SAFETY

This section explains precautionary measures to be taken to avoid injury to the users of this device and others, and to prevent damage to property. Please familiarize yourself with this information to ensure safe operation of this equipment.

	Warning	Failure to follow instructions highlighted with this mark could result in death or severe injury.
	Caution	Failure to follow instructions highlighted with this mark could result in injury or damage to property.
		This mark indicates actions that are prohibited.
		This mark indicates instructions that must always be followed.

Warning

 Prohibited	This monitor must not be used by people with pacemakers or other medical implants. This monitor passes a weak electrical current through the body which could interfere with and cause the malfunction of electrical medical implants, resulting in serious harm to the user.
	Interpretation of measurements (e.g. evaluation of measurements and formulation of exercise programmes based on the measurements) must be performed by a professional. Implementing weight loss measures and exercise programmes based on self-analysis could be harmful to your health. Always follow the advice of a qualified professional.
	Do not step on the edge of the platform. Do not jump onto, or on the monitor. Doing so may cause you to fall or slip, resulting in serious injury.
	Do not place this monitor on a slippery surface such as a wet floor. Doing so may cause you to fall or slip, resulting in serious injury. It may also cause water to get inside the monitor resulting in damage to internal components.

Caution

 Prohibited	Do not stand on the display screen or control panel.
	Do not insert your fingers into gaps or holes. Doing so may result in injury.
	Do not use rechargeable batteries. Do not use old batteries together with new batteries, or a mix of different types of batteries at the same time. Doing so may cause battery fluid to leak or the batteries to become excessively hot and rupture, resulting in damage to the monitor or injury.
	Never allow an infant or small child to carry the monitor. Store out of reach of small children. The child may drop the monitor, resulting in injury. Small children may become caught up in the cables, resulting in injury.
	This monitor is intended for home use only. This monitor is not intended for professional use including hospitals, medical or fitness facilities. It is not equipped with the components required for heavy usage. Using the monitor in a professional location will invalidate the warranty.
Do not pull out the cable unless using the monitor for measurement, as doing so may damage the monitor. Do not pull out the cable beyond the red mark. Do not pull the cable too forcefully. If the cable does not automatically return into the monitor unit, untwist the cable, pull it out approximately 20cm and then try returning it again.	

Place the monitor on a hard, flat surface where there is minimal vibration to ensure safe and accurate measurement.

Avoid excessive impact or vibration to the monitor.

Doing so may damage the monitor or cause it to malfunction, or may cause setting to be erased.

Do not use or store this monitor in the following locations.

- Locations that are exposed to direct sunlight, near to heaters, or exposed directly to air from air conditioning units, etc.
- Locations where there are severe temperature changes or a large amount of vibration.
- Locations with high levels of humidity or moisture.

Doing so may damage the monitor or cause it to malfunction.

Do not step on the monitor when your body is wet (immediately after a shower or bath, etc.)

Be sure to thoroughly dry your body and feet before using the monitor. Failure to do so may cause you to slip or fall, resulting in injury. Also, the monitor cannot take accurate measurements if your body or feet are wet.

Keep away from water.

Do not use boiling water, benzene, thinner, etc. to clean the monitor.

If the monitor becomes dirty, soak a soft cloth in water or neutral household detergent, wring it out thoroughly and wipe the monitor clean, then use a dry cloth to wipe the monitor dry.

Do not attempt to disassemble the monitor. Do not modify this equipment in any way.

Do not wash the monitor in water.

Do not submerge this monitor in water.

Doing so may damage the monitor or cause it to malfunction.

Be sure to insert the batteries with the polarities (+, -) in the correct position.

If the batteries are incorrectly inserted, battery fluid may leak and damage the floor. (If you do not intend to use this monitor for a long period of time, it is advisable to remove the batteries before storage.)

Do not use the monitor near other products such as microwave ovens that emit electromagnetic waves.

Doing so may cause the monitor to malfunction, preventing accurate measurements.

Another person should assist persons with disabilities who may not be able to take a measurement alone.

Avoid measuring after over-eating or over-drinking, or when severely dehydrated.

This may cause inaccurate measurements. For greater accuracy, avoid using directly after waking up. Use at the same time of day each time, at least two hours after the last meal.

Avoid taking measurements after spending time in a sauna, bath or after intense exercise.

This may cause inaccurate measurements. Please take measurements after sufficient rest.

Avoid taking measurements when your physical condition is poor (hangover, diarrhea, fever, etc.).

Doing so may cause error in the measured value. Resume measuring once you have recovered.

Perform measurement with as little clothing on as possible.

Weight of clothing worn will be included in measurements.

Be sure that your toes and heels are correctly aligned with the electrodes on the measurement platform.

The body fat percentage displayed may be low or result in an "Error" (error) display if contact between the electrodes and the soles of the feet is poor.

If you do not undress, always remove your socks or stockings, and be sure the soles of your feet are clean before stepping on the measuring platform.

Use in a stable location. Errors in measurements may occur if the device is used in an unstable location.

An accurate reading will not be possible if your knees are bent or you are in a sitting position.

Do not move during measurement.

This causes inaccurate measurements.

Ensure arms are not touching sides and inner thighs are not touching each other during measurement. If necessary, place a dry towel between arm and side and/or between thighs.



Always...

GETTING ACCURATE READINGS

To ensure accuracy, readings should be taken without clothing and under consistent conditions of hydration. If you do not undress, always remove your socks or stockings, and be sure the soles of your feet are clean before stepping onto the measuring platform. Be sure your heels are correctly aligned with the electrodes on the measuring platform. Don't worry if your feet appear too large for the unit, accurate readings can still be obtained if your toes overhang the platform. It is best to take readings at the same time of day. Try to wait about three hours after rising, eating, or exercising before taking measurements. While readings taken under other conditions may not have the same absolute values, they are accurate for determining the percentage of change as long as the readings are taken in a consistent manner. To monitor progress, compare weight and body fat percentage taken under the same conditions over a period of time.

Note: An accurate reading will not be possible if the soles of your feet are not clean, or if your knees are bent or you are in a sitting position.

- Press  to turn on the power while the control panel is housed in the main unit.
- Measurement cannot be performed accurately if you take out the control panel and hold it or if it is outside the main unit and touching the floor before **"0.00kg"** is displayed.
- Once **"0.00kg"** is displayed, grasp the hand grip and remove the control panel from the main unit.
- Lower your arms, keeping them extended straight in front of you.
- Do not allow your hands or the hand grip to touch your legs or any other part of your body.
- When performing measurements without clothes on, make sure your arms do not make contact with your body and that your stance is wide enough that your legs don't touch. Failure to do so may prevent correct measurements.

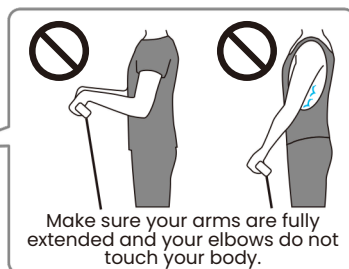
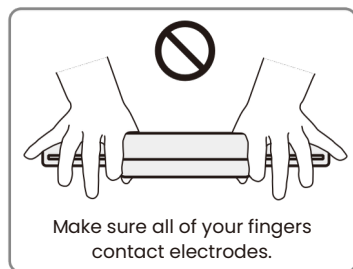
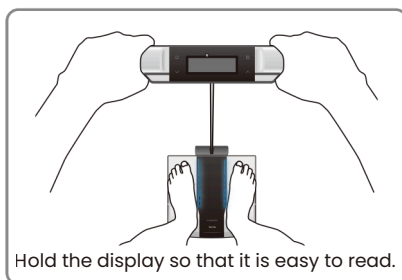

***Do not pull out the cable beyond the red mark.**

PREPARATION BEFORE USE

Inserting the Batteries

Note:

- Be sure that the batteries are inserted in the correct orientation. If the batteries are inserted incorrectly, fluid may leak from the batteries and damage the floor.
- If you do not intend to use this unit for a long period of time, remove the batteries before storage.
- The included batteries from factory may have decreased energy levels over time.

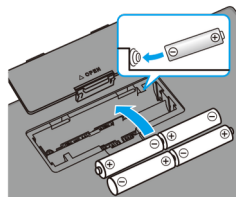

Changing the Weighing Unit

1. When the power is off, press and hold the \wedge button for more than three seconds.
2. Use the $\wedge \vee$ button to switch the weighing unit.
3. Press the \bullet button.

Note:

Only for use with models that have the unit switching button.

Note:

If weighing unit is set to pounds or stone-pounds, the height programming mode is automatically set to feet and inches.

Similarly, if kilograms is selected, height is automatically set to centimeters.

Set Your Location Code

Different locations across the world have different gravitational pulls. These differences affect the accuracy of the weight measurement. You can obtain the most accurate weight readings by selecting the correct gravity setting on the monitor according to your geographical location.

1. When the power is off, press and hold the power button.
2. Refer to the map enclosed, and press the $\wedge \vee$ buttons to select your location code.
3. Press the \bullet button to enter and save the setting.

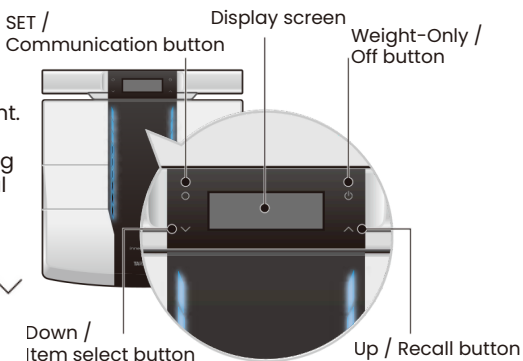

Setting the Date and Time

1. Press and hold the \vee button for more than three seconds.
2. Select the year using the \wedge and \vee buttons.
3. Press \bullet to confirm.



Set the day and hour in the same way.

The power automatically turns off after displaying the set region, year, month, day and time.

INITIAL SETUP (TYPE 1) SETUP VIA SMARTPHONE

1. Turn the Bluetooth® setting on.

Use the URL's below to download the My Tanita app.

Click here:



Note:

- If you are not using an app, enter settings manually in the body composition monitor (pg. 10) before using.
- If you purchase a new smartphone, be sure to adjust the registration of your body composition monitor accordingly.
- Approximate signal range: 5m in areas without obstructions

2. Launch the app.

You need to register as a member to use the My Tanita app.

After registering, login with your registered details.



3. Select "Input Data", then select "Input from BCM".

Select "RD-545" in the next screen.



4. Press and hold the "O"-button or "Sync / Pair"-button and follow instructions in the app.

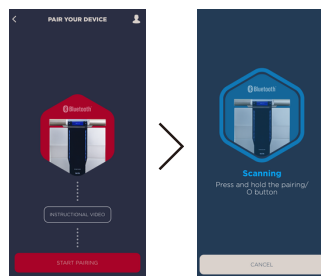

Note:

- Compatible apps may be changed or added, in which case screen displays and operation methods will vary accordingly. Contact info@tanita.eu with any questions or concerns.
- The screen displays and instructions may differ depending on the app specifications.

INITIAL SETUP (TYPE 1) SETUP VIA SMARTPHONE

5. Operate the body composition monitor as indicated by the app.

If the body composition monitor is not powered on, press and hold **O** (enter button) for 3 seconds or more, then enter your information as indicated by the app.



Note:

- Depending on signal strength, it may take a few seconds to connect to the body composition monitor.
- The  icon is lit while data is being transmitted.
- To weigh yourself while holding a smartphone, first enter the amount of weight you want to subtract into "Weight of Clothing, etc." The input amount will be subtracted from your weight display.
- If 0.20 kg is entered into "Weight of Clothing, etc.," the following will be displayed before a measurement is taken.



Display before measurement

6. When the body composition monitor is activated, "0.00kg" is displayed.



7. After "0.00kg" is displayed, hold the control panel and carefully step barefoot onto the measuring platform.

Note:

- Please refrain from moving during measurement.
- Measurements cannot be taken accurately if the control panel is held or resting on the floor before is displayed.





Registration of your body composition monitor is completed once measurement is completed.

INITIAL SETUP (TYPE 2) MANUALLY WITHOUT SMARTPHONE

You first need to enter your personal information (date of birth, sex, height, weight and body composition) before you take a measurement. Once this information has been registered, it is recalled when you turn the power on and step on the body composition monitor, enabling you to use the device easily every day without the hassle of entering information each time.

Body composition must be registered. Only take measurements while barefoot.
Place the body composition monitor on a hard, flat, stable surface.



ID Number Registration

1. With the control panel stored in the body of the device, press  to turn the power on.
2. After "0.00kg" is displayed, press **O**.
3. Select your ID number (1-4) using the  and  buttons.
4. Press **O** to confirm.

Note:



- The backlight color changes depending on the registered ID.

- | | | | | |
|---|---|---|---|---|
|  |  |  |  |  |
| 1. Blue | 2. Pink | 3. White | 4. Sky Blue | Guest: Purple |

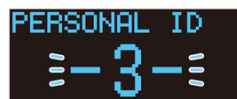
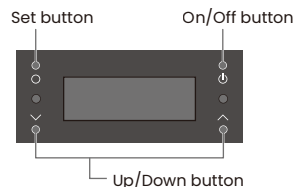
- If any information is registered incorrectly, briefly turn off the device by pressing .
- After turning it back on, press **O** and re-enter your information from the beginning.
- Press  to cancel a selection or turn off the power.





Date of Birth Registration

1. Select your birth year using the  and  buttons.
2. Press **O** to confirm.



Note:

1900 is the earliest year that can be set.



1. Select your birth month using the  and  buttons.
2. Press **O** to confirm.



1. Select your birth day using the  and  buttons.
2. Press **O** to confirm.

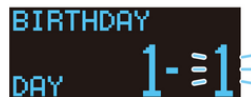

INITIAL SETUP (TYPE 2) MANUALLY WITHOUT SMARTPHONE

Gender Registration

1. Select your gender (male/female/male athlete/ female athlete) using the \wedge and \vee buttons.
2. Press **O** to confirm.

GENDER
MALE
AGE 30

Who should use Athlete Mode?

Adults aged 18 years and over who either:

- Train or exercise for 12 hours or more a week and have been doing so for at least six months.
- Are body builders.
- Are professional athletes who want to monitor their progress at home.
- Have a lifetime history of fitness and who used to do more than 12 hours a week but do less now.

Height Registration

1. Select your height using the \wedge and \vee buttons.
2. Press **O** to confirm.

HEIGHT
160 cm

Heart Rate Measurement (Applicable age 5-99)

1. Press \wedge or \vee to turn the heart rate measurement function ON or OFF.
2. Press **O** to enter the setting.

HEART RATE
ON/OFF

Body Composition Registration

After **"0.00kg"** is displayed, remove the control panel from the device and carefully step barefoot onto the measuring platform.

Lift the grip
0.00 kg

Note:

- Please refrain from moving during measurement.
- Measurements cannot be taken accurately if the control panel is being held or resting on the floor before **"0.00kg"** is displayed.

The device automatically turns off after registered personal data and measurement results have been displayed.

Note:

You must connect your smartphone to the body composition monitor to use an app. Set up the body composition monitor according to the "Setup via Smartphone" instructions. (pg. 8)

TAKING MEASUREMENTS

Go to MY MEASUREMENTS and click 'START MEASUREMENT'. Follow instructions in the app.

After **"0.00kg"** is displayed, hold the control panel and carefully step barefoot onto the measuring platform.

Note:

- Please refrain from moving during measurement.
- Measurements cannot be taken accurately if the control panel is held or resting on the floor before **"0.00kg"** is displayed.



Measurement data is automatically sent to the smartphone.

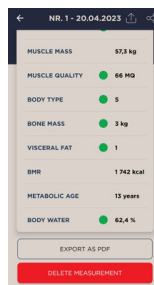

Note:

- To weigh yourself while holding a smartphone, first enter the amount of weight you want to subtract into "Weight of Clothing, etc.," The input amount will be subtracted from your weight display.
- If 0.20 kg is entered into "Weight of Clothing, etc.," the following will be displayed before a measurement is taken.



Display before measurement

- Up to 2 kg can be entered for "Weight of Smartphone, etc."
- The amount entered in "Weight of Smartphone, etc." is subtracted from your measured weight (0-200 kg)

If you do not have your smartphone when taking measurements.

Turn the power on by pressing the  button while the control panel is stored in the device. Data from up to 10 measurements can be stored in this device.



Note:

Up to 10 measurements can be stored in the device per ID number. Each new data entered after this amount causes the oldest data to be deleted.

TAKING MEASUREMENTS WITH AUTO-RECOGNITION

What is the Auto-Recognition Function?

This function automatically recalls registered users and displays their results after they turn on the device, hold the control panel and step onto the measuring platform. This feature reduces hassle by eliminating the need to specify the user every use.

Note:

The auto-recognition function may automatically transition you to ID selection mode in situations such as those listed below:

- When measuring similar body sizes or weights
 - When a change of weight has occurred after several days without a measurement
- If such situations continue, specify the ID number before measuring (pg. 21).

Use this device only with your bare feet and on a hard, flat, stable floor.

1. Press  to turn on the power without removing the control panel from the device.

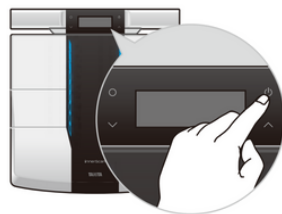

2. After "0.00kg" is displayed, remove the control panel from the body of the device and carefully step barefoot onto the measuring platform.



Note:

- Please refrain from moving during measurement.
- Measurements cannot be taken accurately if the control panel is being held or resting on the floor before is displayed.
- In order to measure with the auto-recognition function, first enter your personal data.(pg. 8)
- Measurements cannot be taken with auto-recognition unless this information is registered.
- The backlight color changes depending on the registered ID.



1.Blue



2.Pink



3.White



4.Sky Blue



Guest: Purple

- The  icon is lit on the personal data display screen once your smartphone has been connected and measurement data has been saved in the device.

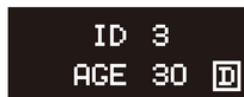

- If more than 6 sets of data have been saved, the personal data display light is lit and the amount of saved data is displayed.



- If you have input a nickname into the app settings, it is displayed in place of the ID number.

Weight is displayed.

WEIGHT
63.45 kg



Measure your body composition and verify it against your registered details.

L.ARM
■ ■ ■ ■ ■
■ ■ ■ ■ ■



:

BOTH HANDS
■ ■ ■ ■ ■



Auto-recognition data is displayed. Please make sure that the displayed data matches your registered content.

Your ID!
ID 3
AGE 30



If heart rate measurement is turned on, the LCD changes to the heart rate measurement screen. Heart rate measurement starts after a countdown. A screen display indicates that heart rate measurement is in progress. Step down from the monitor when you hear a series of short beeps.

HEART RATE
3



The device automatically turns off after measurement results have been displayed. (Reviewing Measurement Results, pg. 18)
Return the control panel to its original position after reviewing your measurement results.

Note:

- If the auto-recognition function discovers multiple possible candidates for the current user, the device automatically switches to the ID selection mode after body composition measurement is complete (pg. 15).
 - Select your ID number using the ^ and v buttons, then press ● to confirm.
- *If the device repeatedly switches to ID selection mode, enter your ID before conducting a measurement (pg. 15).
- If you forget to turn off the power, the device automatically turns off (display turns off) in the following cases:
 - If no operations are performed on measuring platform for more than 60 seconds.
 - If no weight is detected on the measuring platform at any time during measurement.
 - If a single measurement result is displayed for more than 40 seconds.

MEASURING WITH AN ID NUMBER

(Call Measurement)

Enter your ID number and take measurements without using auto-recognition.

Use this method if using auto-recognition repeatedly causes the device to switch to ID select mode, etc.

Place the body composition monitor on a hard, flat, stable floor.

1. Press  to turn on the power without removing the control panel from the device.

2. After **"0.00kg"** is displayed, press .

3. Select your ID number using the ^ and v buttons.

4. Press **O** to confirm.

5. After **"0.00kg"** is displayed, remove the control panel from the device and carefully step barefoot onto the measuring platform.

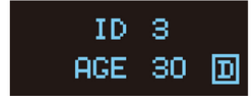

Note:

- Please refrain from moving during measurement.
- Measurements cannot be taken accurately if the control panel is being held or resting on the floor before is is displayed.

6. Step off the measuring platform when you hear it beep.

The device automatically turns off after measurement results have been displayed. When you are finished reviewing your measurements, return the control panel to its original position.



Note:

- If you have entered a nickname into the app settings and connected the body composition monitor to your smartphone, your nickname is displayed instead of your ID number.
- If you step onto the measuring platform before is displayed, **Error** or **-OVERLOAD** is displayed and the power turns off during measurement.

TAKING MEASUREMENTS WITHOUT REGISTERING (Guest User Measurements / Weight-Only Measurements)

Guest User Measurements

1. Press **⏻** to turn on the power without removing the control panel.
2. After **"0.00kg"** is displayed, press **^**, select **GUEST** and press **⏻** to confirm.
3. Select your age, followed by your gender, height and heart rate using the **^** and **∨** buttons.
4. After the information you have entered has been displayed and **"0.00kg"** is displayed, remove the control panel from the device and carefully step barefoot onto the measuring platform.

Note:

- Please refrain from moving during measurement.
- Measurements cannot be taken accurately if the control panel is being held or resting on the floor before **"0.00kg"** is displayed.

5. Step off the measuring platform when you hear it beep.

The device automatically turns off after measurement results have been displayed. When you are finished reviewing your measurements, return the control panel to its original position.

Note:

Age can be set from 5 to 99.

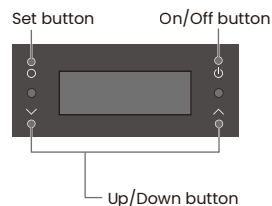

Weight Only Measurements

1. Press **⏻** to turn on the power without removing the control panel from the device.
2. After **"0.00kg"** is displayed, step onto the measuring platform without holding the control panel.
3. If you hear a beep when your weight is displayed, step off the measuring platform.

Note:

- Although **Lift the grip** is displayed, step onto the monitor without holding the control panel.

This method is most convenient for one-time users as personal data and measurement results are not stored.

Note:

- If the auto-recognition function discovers multiple possible candidates for the current user, the device automatically switches to the ID selection mode after body composition measurement is complete (pg. 15).

Select your ID number using the **^** and **∨** buttons, then press **⏻** to confirm.

*If the device repeatedly switches to ID selection mode, enter your ID before conducting a measurement (pg. 15).

- If you forget to turn off the power, the device automatically turns off (display turns off) in the following cases:
 - If no operations are performed on the measuring platform for more than 60 seconds.
 - If no weight is detected on the measuring platform at any time during measurement.
 - If a single measurement result is displayed for more than 40 seconds.

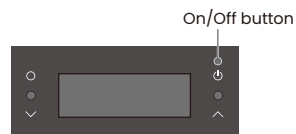

ID SELECTION MODE

If the auto-recognition function discovers multiple possible candidates, the device automatically switches to ID selection mode after body composition measurement.

(The device beeps)

Select your ID number using the \wedge and \vee buttons, then press \bullet to confirm.



If you notice that your ID number is incorrect while you are viewing your results, press \wedge for 3 seconds or more to switch to the ID selection mode and re-select your ID.

Note:

- If you turn off the power without re-selecting your ID number, those measurement results are saved to the incorrect ID number.
- The backlight color changes depending on the registered ID.



1.Blue



2.Pink



3.White



4.Sky Blue



Guest: Purple

MEASUREMENT IN PROGRESS

The mobitor and the control panel light up depending on the area being measured. This is a useful indication of the progress of the current measurement.



Ex: Measuring the right side of the body

REVIEWING MEASUREMENT RESULTS

(Whole Body)

Measurement results are displayed after your personal information. Each item is displayed for approximately 4 seconds before switching to the next item. Assessment items are lit in the order of personal registration color then assessment color before switching to the next item. Finally, your weight is displayed and then the power turns off after about 40 seconds.

- The displayed item can be switched by pressing \wedge or \vee while measurement results are being displayed.
- The \updownarrow icons on the measurement result screen indicate either a positive or negative change since the last measurement was taken.

12. BMI

BMI \downarrow
22.0

11. Body Water (%)

BODY WATER \uparrow
66.6%

10. Bone Mass

BONE MASS \uparrow
2.8kg

9. Basal Metabolic Rate

BMR \uparrow
1527 kcal

8. Metabolic Age

M-AGE \downarrow
23

7. Visceral Fat

VISCERAL-F \downarrow
5.5LV

1. Weight

WEIGHT \uparrow
63.45kg

2. Muscle Mass*

MUSCLE-M \uparrow
54.65kg



Press \bullet to view measurements of a specific area

3. Muscle Quality Score*

MUSCLE-Q \uparrow
67 Pt



Press \bullet to view measurements of a specific area

4. Heart Rate

HEART RATE \downarrow
68 bpm

This is only displayed when the heart rate measurement function is ON.

5. Body Fat (%)*

BODY FAT \downarrow
13.8%



Press \bullet to view measurements of a specific area

6. Physique Rating

PHY
5

REVIEWING MEASUREMENT RESULTS

(By body part)

Press **O** while results are being displayed for muscle mass, muscle mass score (muscle-quality), or body fat percentage measurements for the whole body to review results for each body part. Press **^** or **v** while individual body part measurement results are being displayed to switch between items.

Measurement result assessments are indicated by the flashing color of the backlight.

Assessments

(Ex: Muscle mass displayed by whole body / body part)

By body part

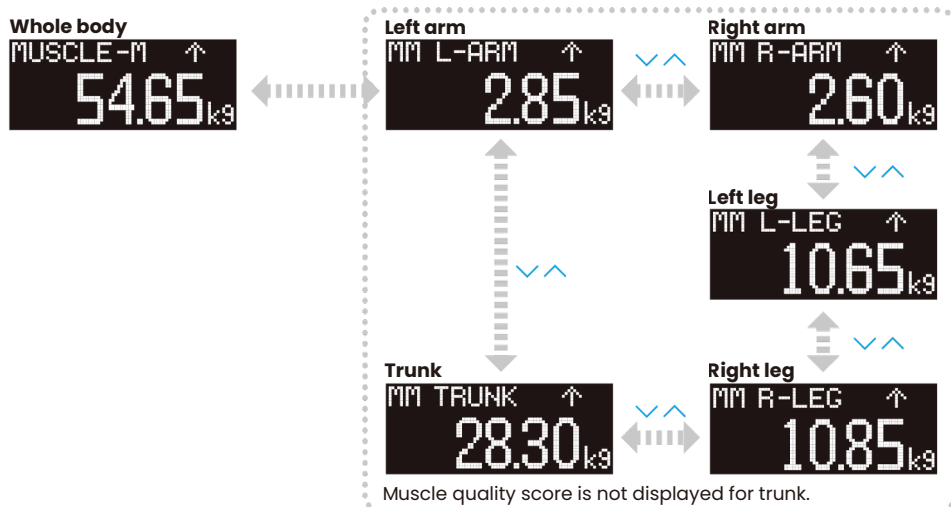

Note:

- "Error" is displayed if the body fat percentage is outside the measurement range.

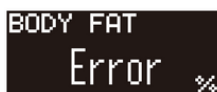

- Persons 17 and younger : Weight, BMI, body fat percentage, and heart rate are displayed.
- To Cancel : Press **U** to cancel a selection or turn off the power.
- The **D** icon is lit on the measurement results display screen once your smartphone has been connected and measurement data has been saved in the device.

Assessments

Measurement result assessments are indicated by the flashing color of the backlight.

Assessment Color	●	●	●
BMI Assessment (*used for weight / BMI)	Obese	Over / Under	Normal range
Body Fat Percentage Assessment	Obese	Over / Under	Standard(-) / Standard(+)
Body Part Fat Percentage Assessment	High	-	Standard / Low
Visceral Fat Level Assessment	High	Slightly High	Average
Muscle Mass Assessment Body Part Muscle Mass Assessment	Under	-	Average / High
Muscle Quality Score Assessment Body Part Muscle Quality Score Assessment	Under	-	Average / High
BMR Assessment (*used for BMR / body age)	Low	-	Average / High

Assistance Function for Accurate Measurement (reference value is for a high heart rate)

When heart rate measurement is enabled on this monitor, heart rate is measured after body composition. If your heart rate is faster than your normal range due to activities such as exercise or bathing, a "✱" (asterisk) will appear next to the measurement in the measurement result screen.

To ensure accurate measurement of body composition, we recommend measuring at a time when your heart rate is at a normal rate, and avoid measuring immediately after exercising or bathing.



 (pg. 12)

- ✱ Is also displayed next to heart rate measurement results for persons aged 5-17, as these are reference values only.

CHANGING PERSONAL DATA

1. Press \downarrow to turn on the power without removing the control panel from the device.
2. After **"0.00kg"** is displayed, press **O**.
3. Select your ID number (1-4) using the \wedge and \vee buttons.

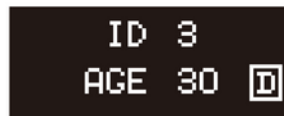

Note:

- If you have entered a nickname into the app settings and connected the body composition monitor to your smartphone, your nickname is displayed instead of your ID number.

4. Press **O** to confirm.

Follow the steps as listed on pg.16 to change your personal data.

Adjusting Date of Birth / Gender

CLEAR is displayed.

1. Select **"YES"** using the \wedge and \vee buttons.
2. Press **O** to confirm.
3. After **"0.00kg"** is displayed, carefully step barefoot onto the measuring platform.
(Measurement procedures, pg. 7)







The power automatically turns off after the adjusted personal data and measurement results have been displayed.

Using the clear function to change personal data via a connected smartphone erases any data saved before the change, as well as any data stored in the device.

Note:

- You must connect your smartphone to use an app.
- Set up the body composition monitor according to the "Setup via Smartphone" (pg. 8) instructions.
- If **"NO"** is selected, data cannot be overwritten.
- Press \downarrow to cancel a selection or turn off the power.
- If you forget to turn off the power, the device automatically turns off (display turns off) in the following cases:
 - If no operations are performed on the measuring platform for more than 60 seconds.
 - If no weight is detected on the measuring platform at any time during measurement.
 - If a single measurement result is displayed for more than 40 seconds.

ERASING PERSONAL DATA

1. Press  to turn on the power without removing the control panel from the device.
2. After **"0.00kg"** is displayed, press **O**.
3. Select the ID number to be deleted using the  and  buttons.
4. Press and hold for more than 3 seconds. **CLEAR** is displayed.
5. Select **"YES"** using the  and  buttons.
6. Press **O** to confirm.

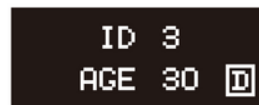

The personal data to be deleted is displayed then deleted.

Deleting personal data connected to a smart phone also causes measurement data to be deleted from the device.

Note:

- Press  to cancel a selection or turn off the power.
- If you forget to turn off the power, the device automatically turns off (display turns off) in the following cases:
 - If no operations are performed on the measuring platform for more than 60 seconds
 - If no weight is detected on the measuring platform at any time during measurement
 - If a single measurement result is displayed for more than 40 seconds

BODY COMPOSITION GUIDE

Who Can Use a Body Composition Monitor?

This Body Composition Monitor is intended for adults aged 18-99 years. Children aged 5-17 years can use the monitor for Weight, BMI, body fat percentage, and heart rate : the other features are not applicable to children.

Thanks to major investment in the latest BIA Technology and sports science research, TANITA has upgraded the Athlete Mode function to make measurements more accurate and suitable for a wider range of users.

Who should use Athlete Mode?

Adults aged 18 years and over who either:

- Train or exercise for 12 hours or more a week and have been doing so for at least six months.
- Are body builders.
- Are professional athletes who want to monitor their progress at home.
- Have a lifetime history of fitness and who used to do more than 12 hours a week but do less now.

Pregnant women should only use the weight function.

Other functions are not intended for use when pregnant. This Body Composition Monitor is intended for home use only. It is not intended for professional use in places such as hospitals or medical or fitness facilities. It is not designed for such heavy usage. Using the monitor in this type of professional environment will invalidate the warranty.

This Body Composition Monitor product provides readings for informational purposes only.

This product is not intended to diagnose or treat any disease or abnormalities. Please consult your physician if you have any questions or concerns related to your health.

How Does a Body Composition Monitor Work?

TANITA Body Composition Monitors calculate your body composition using Dual Frequency Bioelectrical Impedance Analysis (BIA). Safe, low-level electrical signals are passed through the body via the TANITA foot pads on the monitor platform. The signal can flow easily through fluids in muscles and other body tissue but meets resistance as it passes through body fat, because body fat only contains a small amount of fluid. This resistance is called impedance. The impedance readings are then entered into medically researched mathematical formulas to calculate your body composition.

The TANITA RD-545HR incorporates medical grade Dual Frequency BIA technology, allowing you to have the highest body composition accuracy in the comfort of your home. Research has shown that using two different bioelectrical impedance frequencies, provides essential data of a person's intracellular and extracellular status. This advanced technology allows greater accuracy when calculating body composition measurements.

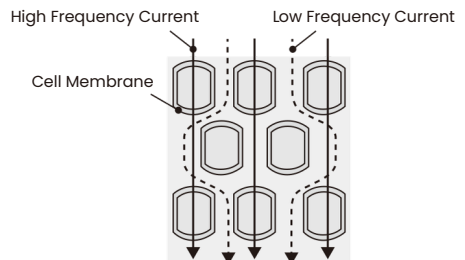

When Is the Best Time To Use My Body Composition Monitor?

Your body water levels naturally fluctuate throughout the day and night. Any significant changes in body water may affect your body composition readings. For example, the body tends to be dehydrated after a long night sleep so if you take a reading first thing in the morning your weight will be lower and your body fat percentage higher. Eating large meals, drinking alcohol, menstruation, illness, exercising, and bathing may also cause variations in your hydration levels.

To get the most reliable reading it is important to use your Body Composition Monitor at a consistent time of day under consistent conditions. A good time to take measurements is before your evening meal.

WHAT IS BODY FAT PERCENTAGE?

(Applicable age 5-99)

Body fat percentage is the amount of body fat as a proportion of your body weight.

Reducing excess levels of body fat has shown to reduce the risk of certain conditions such as high blood pressure, heart disease, diabetes and cancer. The chart below shows the healthy ranges for body fat.

Body Fat Ranges for Standard Children^{1,2} Body Fat Ranges for Standard Adults^{3,4}

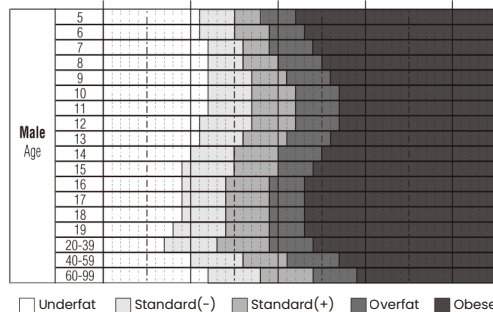
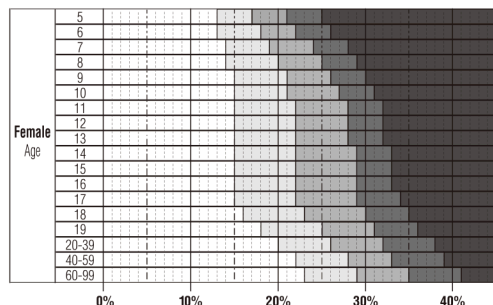

□ Underfat □ Standard (-) □ Standard (+) □ Overfat □ Obese

¹Susan Jebb et al. New Body Fat Reference Curves for Children. Obesity Research 2004; 12:A156-157

²HD McCarthy et al. Body Fat Reference Curves for Children. Int J Obes 2006; 30: 598-602

³Gallagher D et al. Healthy percentage body fat ranges: an approach for developing guidelines based on body mass index. Am J Clin Nutr 2000; 72: 694-701

⁴Based on NIH/WHO BMI Guidelines

Your Body Composition Monitor automatically compares your body fat percentage reading to the Healthy Body Fat Range chart.

Underfat: below the healthy body fat range. Increased risk for health problems.

Standard (-)/Standard (+): within the healthy body fat percentage range for your age/gender.

Overfat: above the healthy range. Increased risk for health problems.

Obese: high above the healthy body fat range. Greatly increased risk of obesity-related health problems.

WHAT IS TOTAL BODY WATER PERCENTAGE?

(Applicable
age 18–99)

Total Body Water Percentage is the total amount of fluid in a person's body expressed as a percentage of their total weight.

Water plays a vital role in many of the body's processes and is found in every cell, tissue and organ. Maintaining a healthy total body water percentage ensures the body functions efficiently and reduces the risk of developing associated health problems.

Your body water levels naturally fluctuate throughout the day and night. Your body tends to be dehydrated after a long night's sleep and there are differences in fluid distribution between day and night. Eating large meals, drinking alcohol, menstruation, illness, exercising and bathing may cause variations in your hydration levels.

Your body water percentage reading should be used as a guide and should not be used to specifically determine your recommended total body water percentage. It is important to look for long-term changes in total body water percentage and maintain a consistent, healthy total body water percentage.

Drinking a large quantity of water in one sitting will not instantly change your body water level. In fact, it will increase your body fat reading due to the additional weight gain. Please monitor all readings over time to track relative changes.

Every individual is different, but as a guide the average total body water percentage ranges for a healthy adult are:

Female: 45 to 60%

Male: 50 to 65%

Source: TANITA Research

Note: The total body water percentage will tend to decrease as the percentage of body fat increases. A person with a high percentage of body fat may fall below the average body water percentage. As you lose body fat, the total body water percentage should gradually move towards the typical range given above.

What Is Visceral Fat Rating?

(Applicable age 18–99)

This function indicates the amount of visceral fat in your body.

Visceral fat is the fat that is in the internal abdominal cavity, surrounding the vital organs in the abdominal area. Research shows that even if your weight and body fat remains constant, as you get older the distribution of fat changes and is more likely to shift to the abdominal area especially post menopause. Ensuring you have healthy levels of visceral fat may reduce the risk of certain diseases such as heart disease, high blood pressure, and the onset of type 2 diabetes.

The TANITA Body Composition Monitor provides you with a visceral fat rating from 1 – 59.
Rating 1 – 12.5

Indicates you have a healthy amount of visceral fat. Continue monitoring your rating to ensure that it stays within this healthy range.

Rating 13 – 59

Indicates you have an excess amount of visceral fat. Consider making changes in your lifestyle by changing your diet or exercising more.

Source : Data from Columbia University (New York) & TANITA Institute (Tokyo)

Note: You may have a high visceral fat level even if you have a low body fat rate.

- Consult a physician for an accurate medical diagnosis.

WHAT IS BASAL METABOLIC RATE (BMR)? (Applicable age 18–99)

Your Basal Metabolic Rate (BMR) is the minimum level of energy your body needs when at rest to function effectively. This includes the functioning of your respiratory and circulatory organs, neural system, liver, kidneys, and other organs. You continue to burn calories even when sleeping.

About 70% of the calories your body uses every day are used by your basal metabolism. In addition, energy is used when doing any kind of activity. The more vigorous the activity, the more calories are burned. This is because skeletal muscle (which accounts for approximately 40% of your body weight) acts as your metabolic engine and uses a large amount of energy. Your basal metabolism is greatly affected by the amount of muscle you have, so increasing your muscle mass helps increase your basal metabolism.

By studying healthy individuals, scientists have found that people's metabolic rate change as they age. Basal metabolism rises as a child grows. After peaking at the age of around 16 or 17, it typically starts to gradually decrease.

Having a higher basal metabolism increases the number of calories used and helps decrease the amount of body fat. A low basal metabolic rate makes it harder to lose body fat and overall weight.

How Does a TANITA Body Composition Monitor Calculate BMR?

The basic method of calculating Basal Metabolic Rate (BMR) is a standard equation that uses weight and age.

TANITA has conducted in-depth clinical research into the relationship of BMR and body composition resulting in a much more accurate and personalized reading for the user based on impedance measurements. This method has been medically validated using indirect calorimetry (measuring breath composition).*

*Reliability of the equation for Basal Metabolic Rate: At 2002 Nutrition Week: Scientific and Clinical Forum and Exposition

Title: International Comparison: Resting Energy Expenditure Prediction Models: The American Journal of Clinical Nutrition.

WHAT IS METABOLIC AGE? (Applicable age 18–99)

This function calculates your BMR and indicates the average age associated with the type of metabolism.

If your metabolic age is higher than your actual age, it is an indication that you need to improve your metabolic rate. Increased exercise builds healthy muscle tissue, which improves your metabolic age.

The reading is shown as a number between 12 and 90. Values under 12 are displayed as "12" and over 90 are displayed as "90".

WHAT IS MUSCLE MASS? (Applicable age 18–99)

This function indicates the weight of muscle in your body. The muscle mass displayed includes skeletal muscle, smooth muscle (such as cardiac and digestive muscle) and the water contained in these muscles.

Muscles play an important role as they act as an engine that consumes energy. As your muscle mass increases, your energy consumption increases helping you reduce excess body fat levels and lose weight in a healthy way.

The muscle mass is judged for persons aged 18 and over.

Muscle mass is judged by calculating the amount of muscle mass against the person's height, and then the amount is classified.

My TANITA app that links with this device displays the muscle mass judgement as a muscle score, as shown below. The larger the number, the more muscle the person has.

Low			Average			High		
-4	-3	-2	-1	0	+1	+2	+3	+4

WHAT IS PHYSIQUE RATING?

(Applicable age 18–99)

This feature assesses your physique according to the ratio of body fat and muscle mass in your body. As you become more active and reduce the amount of body fat, your physique rating also changes accordingly. Even if your weight does not change, your muscle mass and body fat levels may be changing to make you healthier and reduce your risk of certain diseases. Each person should set their own goal of which physique they want to achieve, and follow a diet and fitness program to meet that goal.

Result	Physique Rating	Explanation of Physique Rating Results
1	Hidden Over fat	Small Frame Over fat
		This person seems to have a healthy body type based on physical appearance. However, they have a high body fat percentage with low muscle mass level.
2	Over fat	Medium Frame Over fat
		This person seems to have a healthy body type based on physical appearance. However, they have a high body fat percentage with low muscle mass level.
3	Solidly-built	Large Frame Over fat This person has both a high body fat percentage and a high muscle mass.
4	Under exercised	Low Muscle and Average Body Fat Percentage
		This person has an average body fat percentage and a less than average muscle mass level.
5	Standard	Average Muscle & Average Body Fat Percentage
		This person has average levels of both body fat and muscle mass.
6	Standard Muscular	High Muscle & Average Body Fat Percentage (Athlete)
		This person has an average body fat percentage and higher muscle mass level than average.
7	Thin	Low Muscle & Low Fat
		Both body fat percentage and muscle mass are lower than average.
8	Slim and muscular	Slim and muscular (Athlete)
		This person has a lower than average body fat percentage while having adequate muscle mass.
9	Very Muscular	Very Muscular (Athlete) This person has a lower than average body fat percentage while having above-average muscle mass.

Source: Data from Columbia University (New York) & TANITA Institute (Tokyo)

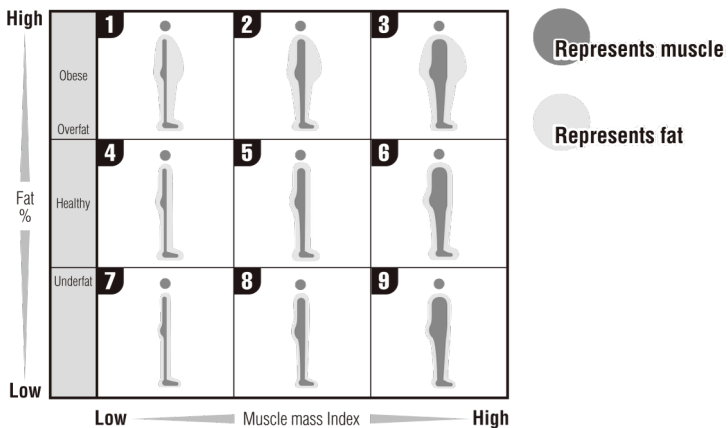

Index of amount of muscle against height = $\text{Muscle mass (Kg)} / \text{height (cm)}^2$

WHAT IS MUSCLE QUALITY SCORE?

(Applicable age 18 - 99)

Muscle quality score indicates the “quality (state) of muscle” which changes according to factors such as age and fitness. The muscles of young people or those who exercise regularly is normally in a good state, but the state of muscles deteriorates in elderly people or those who do not get enough exercise.

Inner Scan Dual Body Composition Monitor uses 2 different frequencies to measure Bioelectrical Impedance, and these results are used to evaluate the muscle state using the Muscle Quality Score.

Male	18 – 29	30s	40s	50s	60s	70s	80 and over
High	74 and higher	73 and higher	70 and higher	64 and higher	56 and higher	46 and higher	39 and higher
Average	49 – 73	47 – 72	44 – 69	39 – 63	33 – 55	25 – 45	21 – 38
Low	48 or less	46 or less	43 or less	38 or less	32 or less	24 or less	20 or less
Female	18 – 29	30s	40s	50s	60s	70s	80 and over
High	68 and higher	70 and higher	69 and higher	67 and higher	61 and higher	54 and higher	50 and higher
Average	48 – 67	48 – 69	45 – 68	41 – 66	34 – 60	26 – 53	22 – 49
Low	47 or less	47 or less	44 or less	40 or less	33 or less	25 or less	21 or less

*Muscle Quality Score may not be accurately evaluated if there are abnormalities in the state of body water, such as in the following conditions:

- If the body fatigued or swollen.
- If the person is dehydrated or suffering from reduced blood flow.

It is important to maintain a good balance between muscle mass and quality.

Balance Between Muscle Mass and Muscle Quality

Muscle Quality Judgement	High	★★		★★★★
	Average	★★		★★★
	Low	★		★★
	Low		Average	High
Muscle Mass Judgement				

Note:

More ★ indicates a better state of muscle.
(Max. ★★★★★)

WHAT IS BONE MASS?

(Applicable age 18–99)

This function indicates the amount of bone (bone mineral level, calcium or other minerals) in the body. Research has shown that exercise and the development of muscle tissue are related to stronger, healthier bones. While it is unlikely that there will be noticeable changes in bone structure over short periods, it is important that you develop and maintain healthy bones by having a balanced diet and plenty of exercise. People worried about bone disease should consult their physician. People who suffer from osteoporosis or low bone density due to age (young or old), pregnancy, hormonal treatment or other causes may not get accurate bone mass readings.

Below is the result of estimated bone masses of persons aged 20 to 40, who are said to have the largest amounts of bone mass by weight.

(Source: TANITA Body Weight Science Institute)

Please use the charts below as a guide for comparing your bone mass readings:

Women: Average of estimated bone mass

Weight (lb)		
Less than 110 lb	110 lb - 165 lb	165 lb and up
4.3 lb	5.3 lb	6.5 lb

Weight (kg)		
Less than 50kg	50 kg - 75 kg	75 kg and up
1.95 kg	2.40 kg	2.95 kg

Men: Average of estimated bone mass

Weight (lb)		
Less than 143 lb	143 lb - 209 lb	209 lb and up
5.9 lb	7.3 lb	8.1 lb

Weight (kg)		
Less than 65 kg	65 kg - 95 kg	95 kg and up
2.66 kg	3.29 kg	3.69 kg

*lb is the estimation calculated based on kg.

Note:

- Persons described below may obtain varying readings and should take the values given for reference purposes only.
 - Elderly persons
 - Women during or after menopause
 - People receiving hormone therapy
- "Estimated bone mass" is a value estimated statistically based on its correlation with the fat-free amount (tissues other than the fat). "Estimated bone mass" does not give a direct judgment on the hardness or strength of the bones or the risks of bone fractures.

If you have concerns over your bones, you are recommended to consult a specialist physician.

WHAT IS BODY MASS INDEX (BMI)?

(Applicable age 5–99)

This function indicates the relationship between height and weight.

The World Health Organization (WHO) considers an index of 18.5 to 25 as optimal for adults.

TROUBLESHOOTING

If you are having problems with your device, check the following information before requesting repairs.

Problem	Check	Reference Page
Nothing is displayed no matter which button is pressed.	<input type="checkbox"/> Are the date and time set correctly? <input type="checkbox"/> Are the batteries worn out? <input type="checkbox"/> Is there plastic or dirt covering the battery terminals?	
" LOW BATTERY " is displayed.	<input type="checkbox"/> Check the orientation of the batteries, and insert them correctly. <input type="checkbox"/> Batteries have become worn. Replace as soon as possible.	5
Text disappears immediately after being displayed.	<input type="checkbox"/> Batteries have become worn. Replace as soon as possible. LOW BATTERY may not be displayed if the remaining battery power is too low.	
The regional settings screen is displayed when a button is pressed.	<input type="checkbox"/> The region, time and date need to be set in order to measure body composition. Set the region, time and date.	5
The date and time setting screen is displayed when a button is pressed.	<input type="checkbox"/> Date and time need to be set in order to measure body composition. Set the date and time.	5
" AGE Error " is displayed.	<input type="checkbox"/> Are the date and time set correctly?	5
" Error " is displayed during measurement.	<input type="checkbox"/> Did you move during measurement?	11
Nothing is displayed when 1 step on the measuring platform.	<input type="checkbox"/> Turn the power on before stepping on the measuring platform.	
Power turns off during measurement (display disappears).	<input type="checkbox"/> Did you step off the measuring platform during measurement?	11-12
" OVERLOAD " is displayed during measurement.	<input type="checkbox"/> The 200kg measurement range was exceeded. (Measurement is not possible in this case).	28
" 0.00kg " is displayed during measurement.	<input type="checkbox"/> Did you step on the measuring platform before "0.00 kg" was displayed? Be sure to wait until "0.00 kg" is displayed before stepping on the measuring platform.	11,13,14
" -OVERLOAD " is displayed during measurement.	<input type="checkbox"/> Are the personal data settings wrong?	6-9
" Error " is displayed as the body composition after measurement.	<input type="checkbox"/> Did you select a different person's ID number?	15
	<input type="checkbox"/> One or more of the measurement items exceeds the measurement range. (Measurement is not possible in this case).	28
The displayed weight measurement is clearly wrong.	<input type="checkbox"/> Be sure to place the device on a hard, flat and stable floor for measurement.	8, 11
Only the weight is displayed.	<input type="checkbox"/> Squeeze the grip tightly.	10, 11
	<input type="checkbox"/> Only the weight is displayed for children 0 to 4 years of age.	28
Body fat percentage is displayed as 5% after measurement.	<input type="checkbox"/> Body fat percentages lower than 5% cannot be measured (displayed as 5%).	28
When measuring with the automatic recognition function a different person's ID number is displayed.	<input type="checkbox"/> Incorrect recognition may occur if multiple people with similar weights and electrical resistivity are registered.	12, 13
Only weight, BMI, body fat percentage and heart rate are displayed.	<input type="checkbox"/> Items other than weight, BMI, body fat percentage and heart rate cannot be displayed for persons aged 5 to 17.	28
Cannot measure body composition even when individual data is set.	<input type="checkbox"/> Individual data settings are incomplete. You need to measure body composition once after entering individual data.	7, 9
" CLEAR " is displayed.	<input type="checkbox"/> This confirmation is displayed when changing or deleting individual data. It is not an Error .	19
A " PAIRING Error " indicating body composition monitor and smartphone cannot be connected is displayed.	<input type="checkbox"/> Are the device and smartphone within communication range? The communication range for the device is 5m with no obstructions.	28
	<input type="checkbox"/> Is "Bluetooth" turned on in the smartphone settings?	6
" PAIRING Error " is displayed a number of times.	<input type="checkbox"/> Delete the device registration from the "Settings" > "Bluetooth" settings on the smartphone, then try pairing the device with the smartphone again.	6
" UUID Error " is displayed.	<input type="checkbox"/> Has the individual data for the connected smartphone been deleted from the body composition device? Delete the device registration from the "Settings" > "Bluetooth" settings on the smartphone, then try pairing the device with the smartphone again.	6
" BLE Error 9 " is displayed.	<input type="checkbox"/> Remove and replace the batteries.	5
The "Measure body composition" button in the app does not work. The "Enter data" button in the app does not work.	<input type="checkbox"/> Is "Bluetooth" turned on in the smartphone settings?	6
	<input type="checkbox"/> The connection between the app and device is only enabled when the device power is off. Check that the device power is off, then try again.	-
An Error is displayed in the heart rate measurement results.	<input type="checkbox"/> Are you measuring in the correct position? <input type="checkbox"/> Did you let go of the grip during measurement? <input type="checkbox"/> If your hands are too dry, wet them a little. <input type="checkbox"/> It may not be possible to measure heart rate for some body types.	9, 12
Body weight is not stable. Body weight is less than usual.	<input type="checkbox"/> If used on a soft surface such as a carpet, the underside of the measuring platform may touch the floor, preventing accurate readings. Perform measurements on a hard, flat and stable floor.	8, 11
The device switches on even though the power has not been switched on.	<input type="checkbox"/> Is a device that has a communication function, microwave oven or other device that emits radio waves such as a wireless telephone being used near the device?	3

Specifications

RD-545HR

Weight Capacity

200kg (440lb/31st6lb)

Weight Increments

0-100kg/0.05kg 100kg-200kg/0.1kg
(0-200lb/0.1lb 200-440lb/0.2lb)
(0-15st0lb/0.1lb 15st0lb-31st6lb/0.2lb)

Applicable Age Range

Total & Segmental Muscle Mass

18-99 years old

Total & Segmental Muscle Quality

18-99 years old

Total & Segmental Body Fat (%)

5-99 years old

Heart Rate

5-99 years old

Physique Rating

18-99 years old

Visceral Fat Rating

18-99 years old

Metabolic Age

18-99 years old

Basal Metabolic Rate

18-99 years old

Bone Mass

18-99 years old

Body Water %

18-99 years old

Body Mass Index

5-99 years old

Personal Data

4 memories

Time accuracy

Within ± 1 minute per month (normal temperature)*

Power Supply

4 × AA Alkaline batteries (included)

Power Consumption

120mA Maximum

Measuring Current

50kHz, 5kHz, 100 μ A

*Normal temperature 23°C \pm 5°C (64.4°F - 82.4°F), Humidity 50% \pm 20%

Representative Tanita Europe B.V.

Hoogoorddreef 56-E

1101 BE Amsterdam

The Netherlands

info@tanita.eu

Tel: +31-20-560-2970

www.tanita.eu

Tanita Corporation of America Inc.

2625 South Clearbrook Drive

Arlington Heights, IL 60005 USA.

Tel: +1-847-640-9241

www.tanita.com

Business Location in UK

The Barn, Philpots Close, Yiewsley,

Middlesex, UB7 7RY,

United Kingdom

Tel: +44(0)1895-438577

Tanita Health Equipment H.K. Ltd.

Unit 301-303 3/F Wing On Plaza,

62 Mody Road, Tsimshatsui East,

Kowloon, Hong Kong

Tel: +852-2838-7111

www.tanita.com

Disposal



This is an electronic device.

Please dispose of it as an electronic device, not as general household waste.

Please follow the regulations in your local region when disposing of this device.



⚠️ Not allowed to mix batteries with consumer wastes!

As consumer you are legally bound to return used or discharged batteries. You can deposit your old batteries at the public collecting points in your town, or wherever the corresponding batteries are sold and specifically marked collecting boxes have been set up. In case of scrapping the apparatus, the batteries should be removed from it and deposited at the collecting points as well.



- The product design and specifications may be changed at any time without prior notice.
- Apple, the Apple logo, and iPhone are trademarks of Apple Inc., registered in the U.S. and other countries. App Store is a service mark of Apple Inc.
- Google Play and the Google Play logo are trademarks of Google LLC.
- Android is trademark of Google LLC.
- The Bluetooth® word mark and logos are registered trademarks owned by Bluetooth SIG, inc. and any use of such marks by TANITA Corporation is under license.

Manufacturer Tanita Corporation 1-14-2, Maeno-Cho, Itabashi-ku, Tokyo, Japan 174-8630 Tel: +81(0)-3-3968-2123 www.tanita.co.jp ISO 9001 Certified
TANITA India Private Limited Level 9, Platina, C-59, G Block, Bandra Kurla Complex, Bandra East, Mumbai 400051, INDIA Tel: +91-22-3953-0507